

FORM - " D "

The Tamilnadu Public Building (Licencing) Act 1965
(Madras Act 13 of 1965) referred to in rule 6 of the
Tamilnadu Public Building (Licencing) Rules 1965.

LICENCE

LICENCE NO. 45/2022

Licence granted to

**THE CORRESPONDENT,
BRILLIANT SCHOOL (SENIOR SECONDARY),
PUDUKKOTTAI ULLUR,
PATTUKKOTTAI TALUK,
THANJAVUR DISTRICT.**

**for the purpose in respect of the building specified in the statement
subject to the conditions and for the period stipulated hereunder**

1. The period of validity of the licence shall be from **23.06.2023
to 22.06.2026**
2. There should be no addition or alteration in the existing

building without prior permission from the competent authority. A
fresh license has to be obtained from the competent authority by the
person concerned in case, if any addition or alteration is made in the
existing building or portion of building for which the license was
granted for the use of building or portion of the building, if originally
changed or altered subsequently

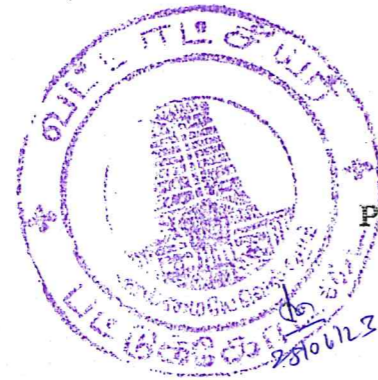

[Handwritten signature in green ink]
**TAHSILDAR
PATTUKKOTTAI**

Proceedings of the Tahsildar, Pattukkottai

=====

Present : Thiru.R.RAMACHANDRAN,B.Sc.,B.L.,

K.Dis. 8113/2023/A7

Dated : 28.06.2023

Sub: The Tamil Nadu Public Buildings (Licencing) Act 1965 – Brilliant School (Senior Secondary-CBSE), Pudhukkottai Ullur village -Pattukkottai Taluk - Form 'D' License – orders issued - regarding

Ref : 1. The Correspondent Brilliant School (Senior Secondary-CBSE), Pudhukkottai Ullur village, Pattukkottai Taluk Application Dated.26.06.2023
2. And other connected records.

Order:

Under the provisions of the sub-section (1) of section 6 of The Tamilnadu Public Building (licencing) Act 1965, Licence granted to

**THE CORRESPONDENT,
BRILLIANT SCHOOL (SENIOR SECONDARY),
PUDUKKOTTAI ULLUR,
PATTUKKOTTAI TALUK,
THANJAVUR DISTRICT.**

for the period from **23.06.2023 to 22.06.2026** in respect of the building mentioned in the statement for running

**BRILLIANT SCHOOL (SENIOR SECONDARY)
PUDUKKOTTAI ULLUR,
PATTUKKOTTAI TALUK,
THANJAVUR DISTRICT.**

the Form "D" license is enclosed herewith.

Ramachandran
**TAHSILDAR
PATTUKKOTTAI**

dm
28/06/23

Statement to Accompany the Licence

Location of the Building / Door No. and Place	Purpose for which the building is licenced to be used as Public Building	Number of persons to be accommodated
PUDUKKOTTAI ULLUR VILLAGE R.S.No.38/11A,38/15 BRILLIANT SCHOOL (SENIOR SECONDARY), PUDUKKOTTAI ULLUR, PATTUKKOTTAI TALUK, THANJAVUR DISTRICT.	PRINCIPAL ROOM, STAFF ROOM, OFFICE ROOM, SMART CLASS ROOMS, LABORATORY, LIBRARY, TIOLET,	1600
	Total	1600

28/06/23
TAHSILDAR,
PATTUKKOTTAI.

28/06/23

PLAN SHOWING THE CONSTRUCTION OF SCHOOL BUILDINGS IN R.S. NOS: 3815 & 11A
AT PUDUKKOTTAI ULLUR VILLAGE, PATTUKKOTTAI TALUK THANJAVUR DISTRICT.

BUILDING NO:1

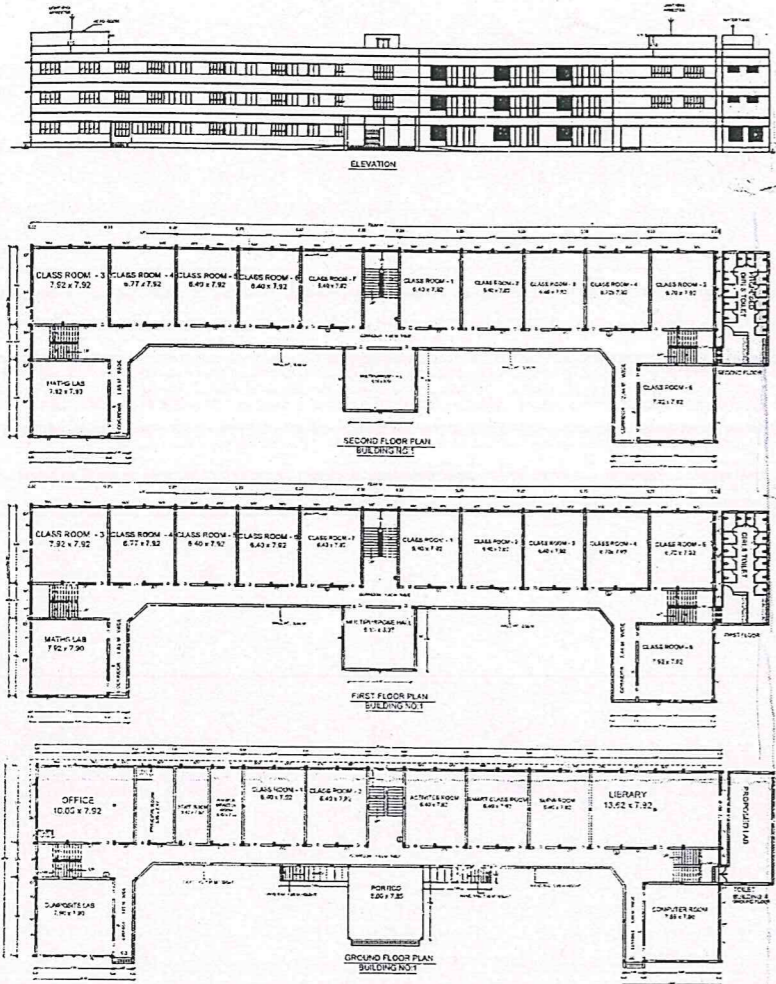

BUILDING NO:2

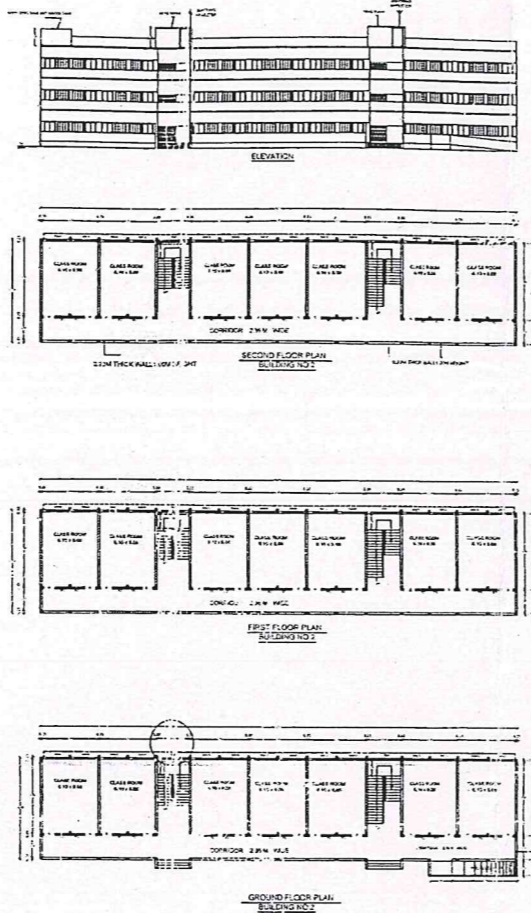

BUILDING NO:3

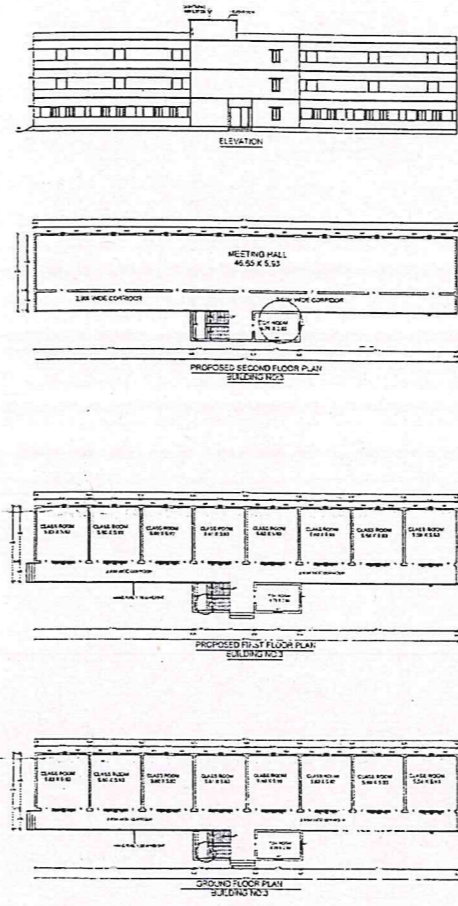

SCHEDULE OF JOINERIES :-

D	Door	1.22 x 2.13m
D1	Door	0.76 x 2.13m
W	Window	2.13 x 1.83m
W1	Window	1.52 x 1.52m
W2	Window	1.22 x 1.22m
V	Ventilator	2.13 x 0.61m
V1	Ventilator	0.61 x 0.91m
V2	Ventilator	1.52 x 0.91m
V3	Ventilator	2.13 x 0.50m
EF	EXHAUST FAN	0.45 x 0.45m

AREA DETAILS :-

CALCULATON	SQ.FT	SQ.M
TOTAL SITE AREA	87555.60	8133.90

Building No:1

Ground floor Area	: 1057.11
First floor Area	: 1057.11
Second floor Area	: 1057.11

Building No:2

Ground floor Area	: 1057.11
First floor Area	: 1057.11
Second floor Area	: 1057.11

Building No:3 (Existing and Proposed)

Extg. Ground floor Area	: 448.60
pro. First floor Area	: 448.60
Pro. Second floor Area	: 448.60

Building No:4 (Existing and proposed)

Extg. Ground floor Area	: 69.71
Extg. First floor Area	: 69.71
Pro. Second floor Area	: 69.71

NUMBER OF CAR PARKING = 30 Nos

FIRE EXTINGUISHER

FIRE ALARMS ARE TO BE PROVIDED

ORIENTATION	REFERENCE :-
N	BOUNDARY
W	EXISTING
E	PROPOSED
S	ROAD

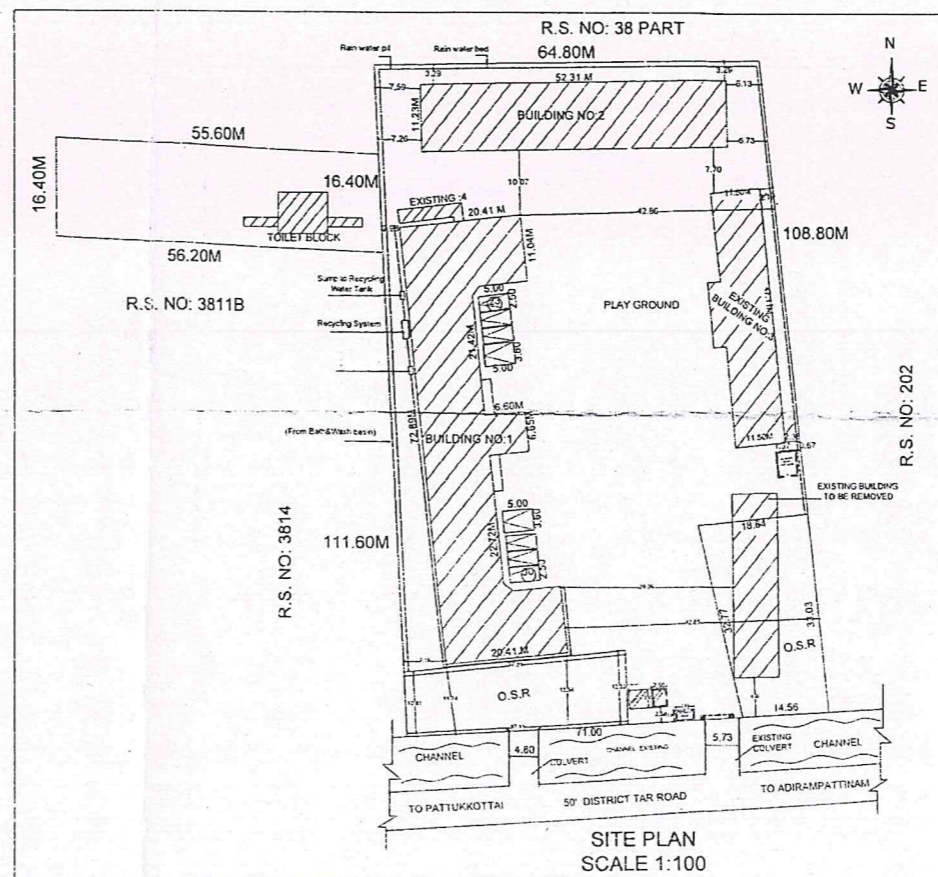
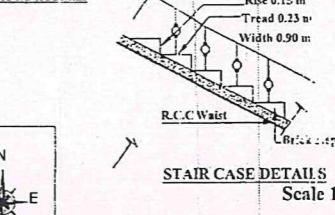
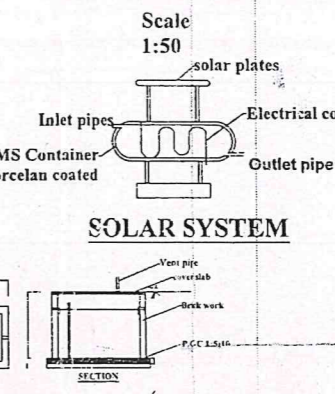
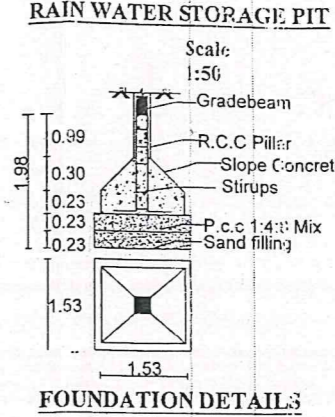
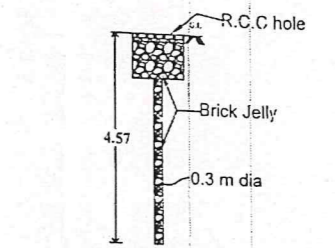

- NOTES:-
1. Plan, Section, Elevation - Scale 1:100
 2. All measurements are in metres.
 3. Certificate that the Rain water Harvesting System shall be Providing as per the norms and condition laid down in.
 4. The G.O.No.198, Municipal Administration and water supply Department dated 11/02/2001
 5. Solar water heater system will be provided
 6. Rain water is connected to rain water pit
 7. U Trap will be provided in all the outlets
 8. Lightning conductors are to be provided.

APPLICANT:-

ENGINEER/LICENSED BUILDING SURVEYOER

[Handwritten Signature]
M. S. SIVAKUMAR
M. S. SIVAKUMAR